

## S - Slave

High performance interchangeable slave interfaces supporting all major industrial networks

- ▶ Profibus
- ▶ Profinet
- ▶ DeviceNet
- ▶ EtherNet/IP
- ▶ ControlNet
- ▶ CANopen
- ▶ CC-Link
- ▶ Modbus-TCP
- ▶ Modbus-RTU
- ▶ EtherCAT
- ▶ Interbus
- ▶ Lonworks
- and more...

## The world's best selling fieldbus interface range supporting 18 industrial networks. Take a closer look at the embedded Anybus-S slave family.

The Anybus-S (slave) modules are designed for integration into industrial field devices that need to communicate with PLC's or PC's via industrial networks. The modules have their own high performance microprocessor which handles the entire communication protocol independently of the host application.

Typical applications for Anybus-S are frequency inverters, HMI and visualization devices, instruments, scales, robotics and intelligent measuring devices.

### Designed for industrial applications, high performance and functionality

All Anybus-S modules have a standardized application interface supporting up to 512 byte of cyclic I/O data and additional support for acyclic parameter data. This is exactly what is required by standard fieldbus protocols such as Profibus-DP or DeviceNet and provides a reserve for future technologies and additional functionality in the host device.

The application interface is fully standardized regarding its mechanics, hardware and software features and thus all Anybus-S modules are easily interchangeable. Data and parameters which are not supported by all fieldbus systems are located in the fieldbus-specific part of the application interface.

Data exchange between the Anybus-S and the field device is handled by control registers, which specify the size of the I/O area and the watchdog interval between the module and the device. In addition, the application software interface provides module related data such as the network type, vendor information, software and hardware versions and the serial number of the module.



Example of a motion controller using Anybus-S Ethernet as its communication card

### Standardized hardware and software interface

The application interface between the Anybus-S module and the host device consists of an on-board 2 KB Dual Port RAM. As all Anybus-S modules have the same hardware and software interfaces, the host device does not need to differentiate between the networks. The view from the host device on to the network is always the same.

The module is connected to the host device with a 34-pin connector. The Dual Port RAM allows the module and the host device to independently address different memory areas. Access to the Dual Port RAM can be interrupt-controlled

or polled from the field device. A handshake mechanism is used between the module and the application program in the device, in order to ensure safe communication and data consistency even when transmitting large continuous data areas (e.g. analog values).

The Dual Port RAM is divided into memory areas for process data In and process data Out, parameter data via mailboxes and control and handshake registers. All areas are fully standardized and independent of the specific network protocol. Accordingly, the application software in the fieldbus device does not need to be modified when changing from one fieldbus type to another. It is only necessary to exchange the Anybus module. Specific fieldbus information can be read/written to the fieldbus specific data area reserved on the module.

#### WHY USE ANYBUS-S MODULES?

- Connectivity to 18 different industrial networks with only one development
- All Anybus-S modules are fully interchangeable with each other
- Same hardware and software interface from the view of the host device
- Up to 70% savings in development costs
- Continuous technology maintenance by HMS
- Short time-to-market, typically only 1-3 months for several networks
- Proven Anybus technology - Over 750,000 Anybus modules sold (Q407)



**Available for:**

- Profibus-DP
- Profibus-DPV1
- DeviceNet
- EtherNet/IP
- Profinet IO
- Profinet IRT
- Modbus-TCP
- ControlNet
- CANopen
- CC-Link
- Modbus Plus
- Modbus-RTU
- FIPIO
- Lonworks
- Interbus
- Interbus Fiber-Optic
- FL-Net
- EtherCAT

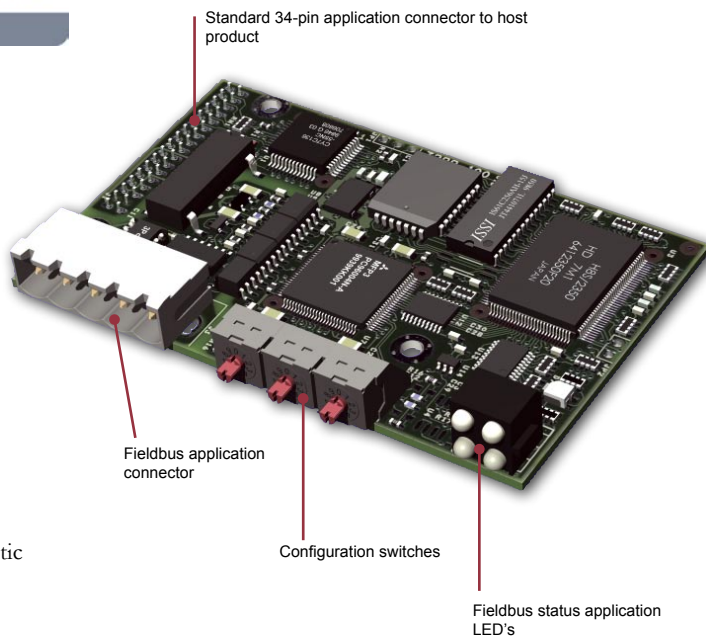

Picture: Anybus-S CC-Link slave interface

**KEY FEATURES**

- Credit card sized interfaces
- Interchangeable interfaces supporting 18 industrial networks
- 2 kbyte Dual Port RAM application interface
- Max 512 byte of cyclic Input data and 512 byte of cyclic Output data
- On-board microprocessor
- 256 byte mailbox interface extendable up to 2048 byte for parameter data
- Drivers and sample code available in C-Source code for easy implementation
- Quick and easy integration with sample code and evaluation board
- On-board power supply and isolation to meet each individual network specification
- Tested and verified for fieldbus conformance

**TECHNICAL SPECIFICATION**

- Size: 86 x 54 x 15 mm (L x W x H)  
2.13 x 3.38 x 0.59" (L x W x H)
- Power supply: +5 V 300 - 450 mA
- Operating temperature:  
0 °C to + 70 °C  
32 °F to + 158 °F
- EMC Compliance: 89/336/ EEC  
Emission: EN 50081-2: 1993  
Immunity: EN 50082-2: 1995  
UL and cUL Compliance: E 209168  
CE-Mark: CE-marked (all versions)
- Tested and verified for network conformance
- RoHS compliance

**Block schematic - Anybus-S slave**

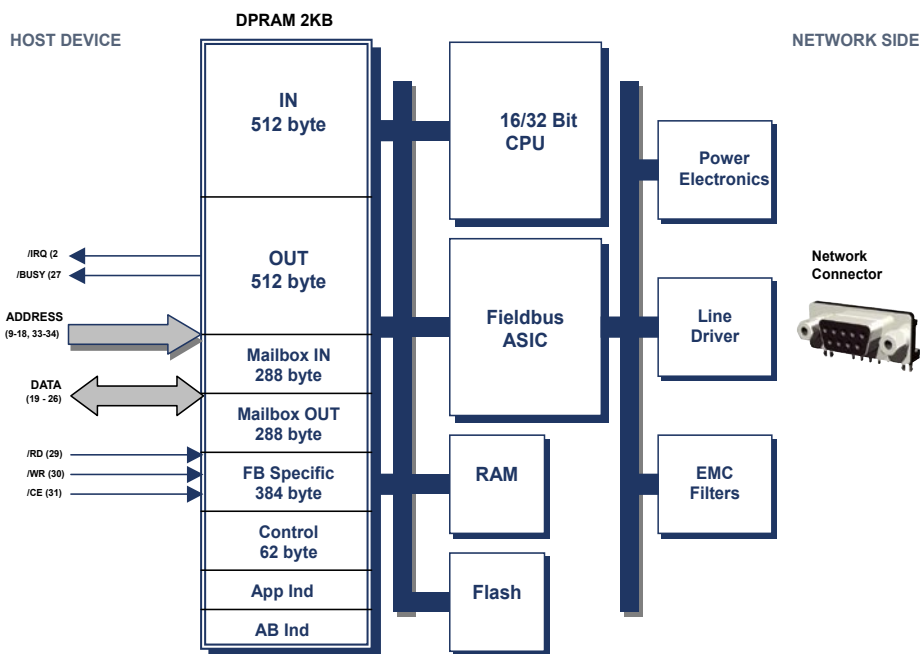

# Network specific supported features - Anybus-S slave family

<p> <b>Profibus-DP AB4005</b></p> <ul style="list-style-type: none"> <li>• Complete Profibus-DP slave functionality</li> <li>• Max 244 byte Input and 244 byte Output. Total max 416 byte In and Out</li> <li>• Automatic baud rate detection (9600 bit/s - 12 Mbit/s)</li> <li>• RS-485 optically isolated Profibus interface with on-board DC/DC converter</li> <li>• Generic GSD file provided</li> </ul>	<p> <b>Profibus-DPV1 AB4174</b></p> <ul style="list-style-type: none"> <li>• Complete Profibus-DPV1 slave functionality</li> <li>• Supports PA baud rate 45 kbit/s</li> <li>• Supports class 1 and class 2 services</li> <li>• Automatic baud rate detection (9600 bit/s up to 12 Mbit/s)</li> <li>• RS-485 optically isolated Profibus interface with on-board DC/DC converter</li> <li>• Generic GSD file provided</li> </ul>	<p> <b>Profinet IO AB4392</b></p> <ul style="list-style-type: none"> <li>• Complete Profinet IO device functionality</li> <li>• Max. 1300 byte of Input and 1300 byte Output data</li> <li>• 100 Mbit/s full duplex transmission</li> <li>• RJ45 connector</li> <li>• Powerful 32 bit processor for short cycle times</li> <li>• Generic GSD file provided</li> <li>• IT functions dynamic web server, E-mail and FTP</li> </ul>	<p> <b>Profinet IRT AB4474</b></p> <ul style="list-style-type: none"> <li>• Complete Profinet IO device with "IRT" functionality</li> <li>• Max. 1300 byte of Input and 1300 byte Output data</li> <li>• 100 Mbit/s fast Ethernet with integrated 2-port real time switch and dual RJ45 connector</li> <li>• Based on Siemens ERTEC</li> <li>• Generic GSD file provided</li> <li>• Available Q4/2007</li> </ul>	<p> <b>DeviceNet AB4004</b></p> <ul style="list-style-type: none"> <li>• Complete DeviceNet adapter functionality</li> <li>• Baud rate: 125-500 kbit/s</li> <li>• Optically isolated DeviceNet interface</li> <li>• Max 512 byte Input &amp; 512 byte Output data</li> <li>• DeviceNet supported features: I/O slave messaging, bit strobe, polling, cyclic and change of state</li> <li>• Generic EDS file provided</li> </ul>	<p> <b>EtherNet/IP AB4173</b></p> <ul style="list-style-type: none"> <li>• Complete EtherNet/IP adapter functionality</li> <li>• IP address settings configurable through on-board DIP switches, web page, DCP or DHCP</li> <li>• Baud rate: 10/100 Mbit/s</li> <li>• Transformer isolated Ethernet interface</li> <li>• IT functions dynamic web server, E-mail and FTP</li> <li>• Generic EDS file provided</li> </ul>
<p> <b>Modbus-TCP AB4172</b></p> <ul style="list-style-type: none"> <li>• Complete Modbus/TCP server functionality</li> <li>• IP address settings configurable through on-board DIP switches, web page, DCP or DHCP</li> <li>• Baud rate: 10/100 Mbit/s</li> <li>• Transformer isolated Ethernet interface</li> <li>• IT-functions: dynamic web server, E-mail and FTP</li> </ul>	<p> <b>ControlNet AB4007</b></p> <ul style="list-style-type: none"> <li>• Complete ControlNet adapter functionality</li> <li>• Network Access Port (NAP) RG-6 quad shielded cable</li> <li>• Media redundancy</li> <li>• Baud rate: 5 Mbit/s</li> <li>• MacID node address setting</li> <li>• Multicasts of both inputs and peer-to-peer data</li> <li>• Generic EDS file provided</li> </ul>	<p> <b>CANopen AB4003</b></p> <ul style="list-style-type: none"> <li>• Complete CANopen slave functionality</li> <li>• Unscheduled data exchange support</li> <li>• Selectable baud rates from 10 kbit/s to 1 Mbit/s</li> <li>• MacID node address setting of up to 127 nodes</li> <li>• Peer to peer messaging</li> <li>• Optically isolated CAN interface</li> <li>• Generic EDS file provided</li> </ul>	<p> <b>CC-Link AB4210</b></p> <ul style="list-style-type: none"> <li>• Complete CC-Link slave functionality</li> <li>• Total 128 I/O points (bit) and 32 words</li> <li>• No of occupied stations: 1-4</li> <li>• Supports profiles for a "Remote Device"</li> <li>• Baud rate: 156 kbit/s - 10 Mbit/s</li> <li>• CC-Link Conformance according to BTP-05027-B specification</li> <li>• Generic CSP file provided</li> </ul>	<p> <b>Interbus AB4294</b></p> <ul style="list-style-type: none"> <li>• Complete Interbus slave functionality</li> <li>• Up to 20 byte of process I/O data PCP V.2.0 (selectable between 0,1,2, or 4 words)</li> <li>• Possibility to define own PCP object with the dynamic mailbox interface</li> <li>• Max amount of PCP data per message: 32 byte via default objects or 58 byte if defining own objects</li> <li>• Baud rate: 500 kbit/s or 2 Mbit/s</li> </ul>	<p> <b>Interbus F.O AB4293</b></p> <ul style="list-style-type: none"> <li>• Complete Interbus slave functionality</li> <li>• FSMA standard connectors conforming to IEC874-2 and DIN47258</li> <li>• Based on OPC chipset with support for optical diagnostics</li> <li>• Transmission media: plastic fibre, core 180 µm, clad 1000 µm; HCS (glass) fibre, core 200 µm, clad 230 µm</li> <li>• Baud rate: 500 kbit/s or 2 Mbit/s</li> </ul>
<p> <b>Lonworks AB4079</b></p> <ul style="list-style-type: none"> <li>• Complete Lonworks slave functionality</li> <li>• FT-X1 transceiver</li> <li>• Configurable amount and type of network variables</li> <li>• Support for self installation</li> <li>• LonMark objects and profiles supported</li> </ul>	<p> <b>Modbus Plus AB4080</b></p> <ul style="list-style-type: none"> <li>• Complete Modbus Plus slave functionality</li> <li>• Global database and peer-to-peer capabilities</li> <li>• Max 256 words of Input and 256 words of Output data</li> <li>• Baud rate: 1 Mbit/s</li> <li>• RS-485 optically isolated Modbus Plus interface</li> <li>• Configuration of node ID and source ID via DIP switches</li> </ul>	<p> <b>Modbus-RTU AB4219</b></p> <ul style="list-style-type: none"> <li>• Complete Modbus RTU slave functionality</li> <li>• Total 512 byte Input and 512 byte Output via DPRAM (up to 2048 byte I/O with internal memory).</li> <li>• Baud rate: 1.2 kbit/s - 57.6 kbit/s</li> <li>• Selectable RS232/RS485 interface via DIP switches</li> </ul>	<p> <b>FL-Net AB4451</b></p> <ul style="list-style-type: none"> <li>• Complete FL-Net device functionality</li> <li>• Supports shielded (STP) &amp; unshielded (UTP) cables</li> <li>• FL-NET Class 1 node</li> <li>• Customizable identity/profile information</li> <li>• Up to 512 byte cyclical I/O in each direction</li> <li>• Transformer isolated Ethernet interface</li> <li>• IP setting via DIP switches</li> </ul>	<p> <b>FIPIO AB4218</b></p> <ul style="list-style-type: none"> <li>• Complete FIPIO slave functionality</li> <li>• Supports all FIPIO profiles and classes</li> <li>• Identity customization</li> <li>• Node address configuration using on board switches or via the application interface</li> <li>• Max. 64 byte Input and 64 byte Output data</li> <li>• Supports both FIP and WorldFIP standards</li> </ul>	<p> <b>EtherCAT AB4455</b></p> <ul style="list-style-type: none"> <li>• Complete EtherCAT node functionality</li> <li>• CANopen over EtherCAT</li> <li>• Real time exchange via PDO's and SDO's</li> <li>• 2x RJ45 connectors</li> <li>• Max. 512 byte PDO data in each direction</li> <li>• Max. 2048 byte SDO data in each direction</li> <li>• Generic EDS file provided</li> </ul>

Customized versions for specific requirements possible - Contact your nearest HMS office



## About HMS

HMS Industrial Networks is the leading independent supplier of network technology for automation devices. HMS develops and manufactures solutions for interfacing automation devices to industrial networks.

Development and manufacturing takes place at the head office in Halmstad, Sweden. Local sales and development support for device manufacturers is provided by the branch offices in Chicago, Beijing, Karlsruhe, Milan, Mulhouse and Tokyo and by a global distribution network spanning 30 countries. HMS employs 138 persons of which 35 in R&D and reported sales of \$30 million in 2006. HMS is ranked in the top 500 fastest growing companies in Europe.

For more information please visit:

[www.anybus.com](http://www.anybus.com)

### Sweden (HQ)

Tel: +46 (0) 35 17 29 00  
Email: [sales@hms-networks.com](mailto:sales@hms-networks.com)  
[www.anybus.com](http://www.anybus.com)

### Germany

Tel: +49 (0) 721 96472-0  
Email: [info@hms-networks.de](mailto:info@hms-networks.de)  
[www.anybus.de](http://www.anybus.de)

### Italy

Tel: +39 (0)39 59662 27  
Email: [it-sales@hms-networks.com](mailto:it-sales@hms-networks.com)  
[www.anybus.it](http://www.anybus.it)

### France

Tel: +33 (0)3 89 32 76 76  
Email: [fr-sales@hms-networks.com](mailto:fr-sales@hms-networks.com)  
[www.anybus.fr](http://www.anybus.fr)

### USA

Tel: +1 312 829 0601  
Email: [us-sales@hms-networks.com](mailto:us-sales@hms-networks.com)  
[www.anybus.com](http://www.anybus.com)

### Japan

Tel: +81 (0) 45 478 5340  
Email: [jp-sales@hms-networks.com](mailto:jp-sales@hms-networks.com)  
[www.anybus.jp](http://www.anybus.jp)

### China

Tel: +86 (0) 10 8532 3183  
Email: [cn-sales@hms-networks.com](mailto:cn-sales@hms-networks.com)  
[www.anybus.cn](http://www.anybus.cn)

Anybus® is a registered trademark of HMS Industrial Networks AB, Sweden, USA, Germany and other countries. Other marks and words belong to their respective companies. All other product or service names mentioned in this document are trademarks of their respective companies.

Part No: MM0004 Version 4 07/2007 - © HMS Industrial Networks - All rights reserved - HMS reserves the right to make modifications without prior notice.